



DFE052 - 6 Way

Solenoid control monoblock diverter valves

- 2 - 3 - 6 - 8 ways configuration
- Galvanized body

This catalogue shows technical specifications and diagrams measured with mineral oil of 46 mm²/s (46 cSt) viscosity at 40°C - (104°F) temperature.

WORKING CONDITIONS		
N. of available ways		2 - 3 - 6 - 8
Max. flow rating		60 l/min (15.8 US gpm)
Max. pressure	without drain	200 bar (2900 psi)
	with drain	315 bar (4600 psi)
Available supply voltage	VDC	see reference page 85
Nominal power		38 W
Internal leakage A(B)⇒T	Δp = 100 bar (1450 psi)	7 cm ³ /min (0.42 in ³ /min)
Fluid		Mineral based oil
Fluid temperature	with NBR (BUNA-N) seals	from -20°C to 80°C (from -4°F to 176°F)
	with FPM (VITON) seals	from -20°C to 100°C (from -4°F to 212°F)
Viscosity	operating range	from 15 to 75 mm ² /s (from 15 to 75 cSt)
	min.	12 mm ² /s (12 cSt)
	max.	400 mm ² /s (400 cSt)
Max. level of contamination		20/18/15 - ISO 4406 - NAS 1638 - class 9
Ambient temperature for working conditions		from -20°C to 50°C (from -4°F to 122°F)

NOTE - For different working conditions please contact Sales Dept.

Available threads

PORTS THREAD			
ALL PORTS	BSP	UN-UNF	METRIC* (ISO 9974-1)
DFE052	G 3/8	3/4-16 (SAE 8)	M18x1.5
PILOT PORTS			
L	G 1/4	9/16-18 (SAE 6) 7/16-20 (SAE 4)**	M12x1.5

(**): for DFE052/8 diverter valves

(*) Optional threads
for availability contact Sales
Department

Dimensional data - hydraulic circuit - performance data

6 ways

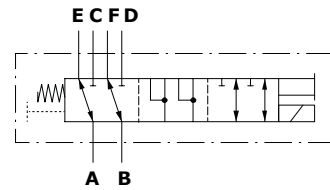
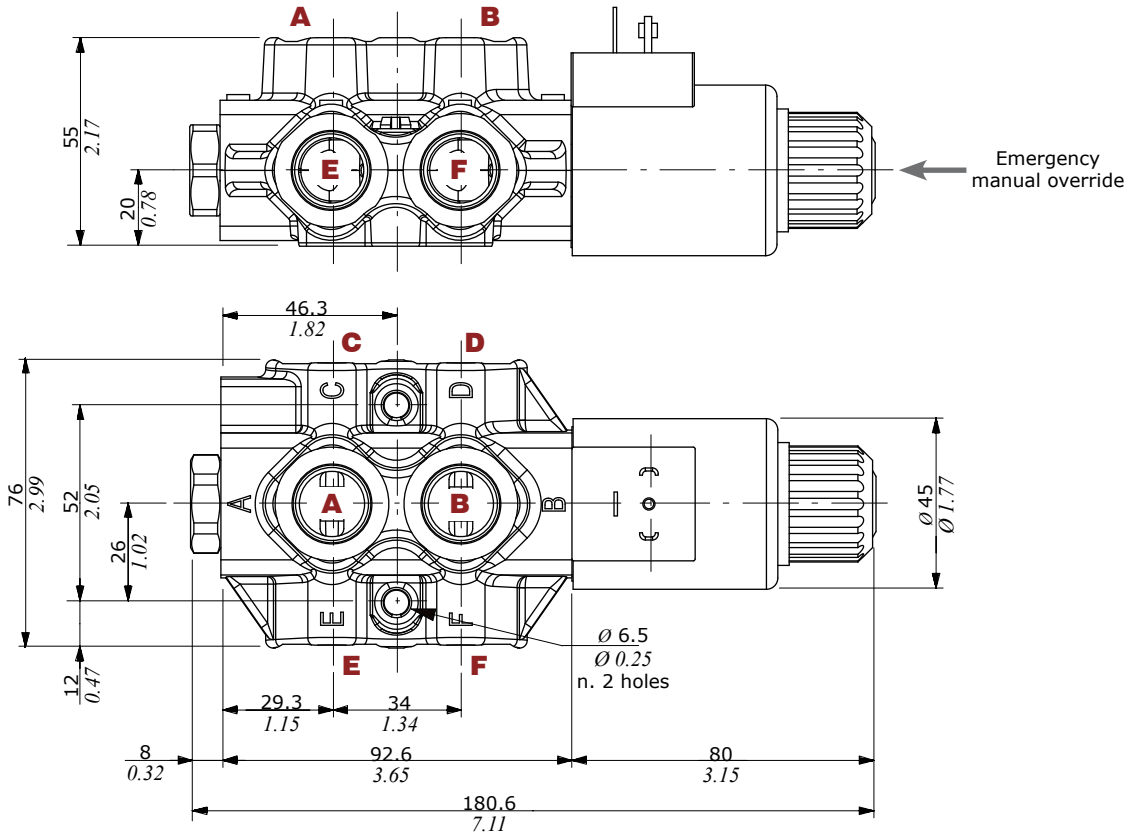

Pressure drop versus flow

A → C(E)

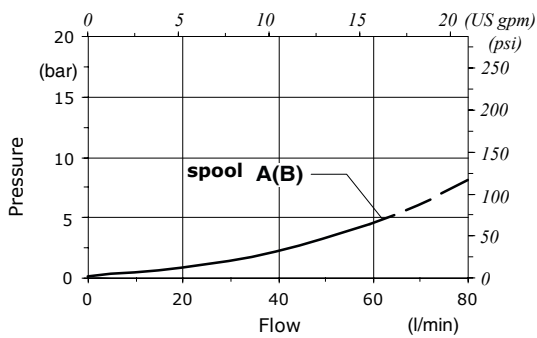

Minimum dynamic conditions

(Supply = Vn-10%, coil at 70 °C - 158 °F)

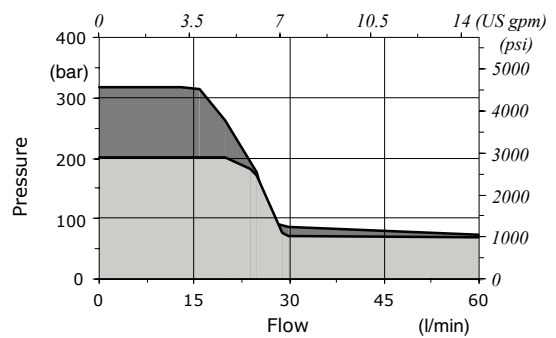

With drain
 Without drain

Part ordering codes

Example:

DFE052/3 A 18 ES - W 2 0 2 - 12VDC - ... - (CRZ)

For description composition see the text below

Coil
1 = without coil
2 = with coil

Connection*
0 = ISO (Std)
2 = AMP-JPT
3 = Deutsch DT06
4 = Deutsch DT04-2P Male
5 = Deutsch DT04-4P Female
6 = Metri-Pack Female
7 = Metri-Pack Male
8 = WeatherPack Male
9 = WeatherPack Female

Length cables
(only if it's present)
Length is in mm

Diode*
(text omitted if diode is not present)
DB = bidirectional diode

Bellow
1 = without bellow
2 = with bellow

Coil voltage

(*) - For diodes and connector options see coils table on page 85

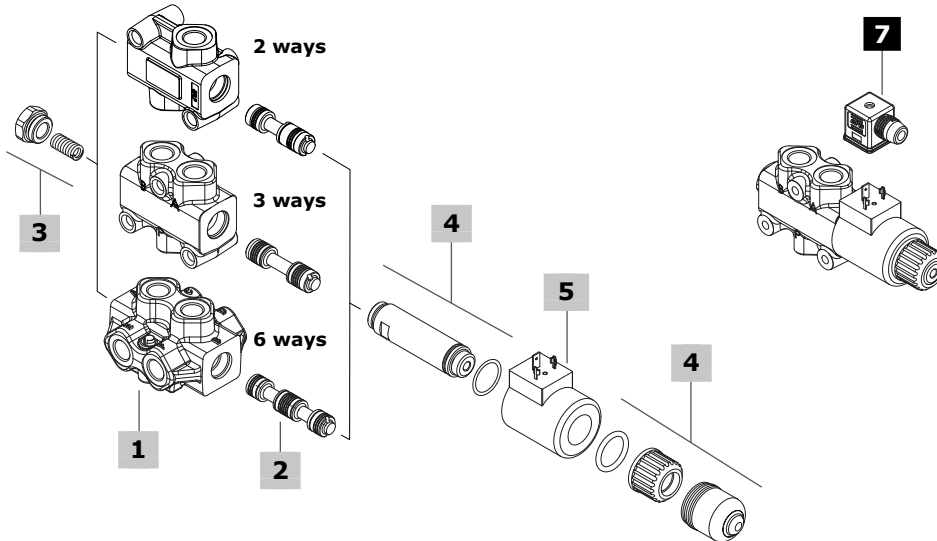

1 Body kit* page 82

TYPE	CODE	DESCRIPTION
DFE052/2	3CO2220321Z	2 ways body kit
DFE052/3	3CO2221325Z	3 ways body kit
DFE052/6	3CO2222326Z	6 ways body kit

2 Spools page 82

TYPE	CODE	DESCRIPTION
for DFE052/2:		
A	3CAS105245	Open port in neutral
B	3CAS105145	Closed port in neutral
for DFE052/3:		
A	3CAS105345	Flow in A in neutral. Ports connected in transit position
B	3CAS105445	Flow in A in neutral. Ports closed in transit position
D	3CAS105546	Closed ports in neutral and connected in transit position
for DFE052/6:		
A	3CAS105645	Flow in E and F. C and D closed in pos. 1 Ports connected in transit position
B	3CAS105746	Flow in E and F. C and D closed in pos. 1 Ports closed in transit position
H	3CAS105845	D<->C in pos. 1, F<->E in pos. 2 Ports closed in transit position

3 Positioner kit page 83

TYPE	CODE	DESCRIPTION
18...W	5TAP001	Spring return in pos. 1
18...Y	5GIU001*	Spring return in pos. 1, with G1/4 drain port

4 Solenoid kit page 84

TYPE	CODE	DESCRIPTION
ES	5SOL515000	Tube assembly without protective bellow
-	4ACC515	Optional tube assembly protective bellow

5 Coil

For list of available coils see pages 85

6 Body threading

Specify threading always when it is different from **BSP** standard

7 Accessories

For list of available connectors see pages 85

(*) - Codes are referred to **BSP** thread

Spool circuits

2 ways

Type A

Open port in neutral position

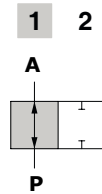

Type B

Closed port in neutral position

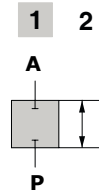

Spool stroke

Position 2: - 4 mm (- 0.15 in)

Spool stroke

Position 2: - 4 mm (- 0.15 in)

3 ways

Type A

Ports connected in transit position

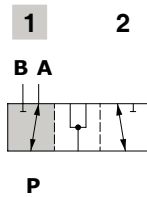

Spool stroke

Position 2: - 4 mm (- 0.15 in)

Type B

Ports closed in transit position

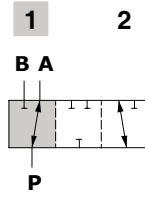

Spool stroke

Position 2: - 4 mm (- 0.15 in)

Type D

Closed ports in neutral and connected in transit position

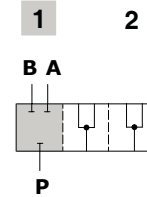

Spool stroke

Position 2: - 4 mm (- 0.15 in)

6 ways

Type A

Flow in E and F. C and D closed in pos. 1
Ports connected in transit position

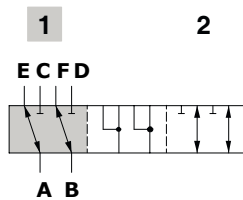

Spool stroke

Position 2: - 4 mm (- 0.15 in)

Type B

Flow in E and F. C and D closed in pos. 1
Ports closed in transit position

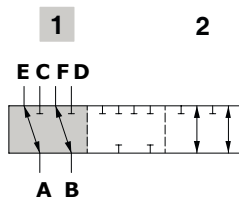

Spool stroke

Position 2: - 4 mm (- 0.15 in)

Type H

D<->C in pos. 1, F<->E in pos. 2
Ports closed in transit position

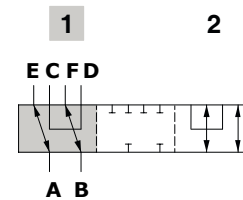

Spool stroke

Position 2: - 4 mm (- 0.15 in)

Spool circuits

8 ways

Type A

Flow in C and D. E, F, G and H closed in pos. 0. Ports connected in transit position

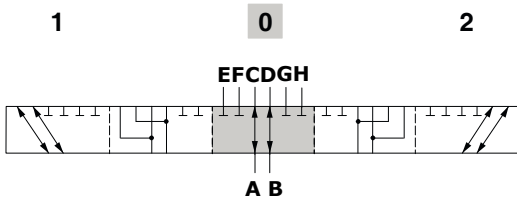

Spool stroke

Position 1: + 3.4 mm (0.13 in)
Position 2: - 3.4 mm (- 0.13 in)

Type B

Flow in C and D. E, F, G and H closed in pos. 0. Ports closed in transit position

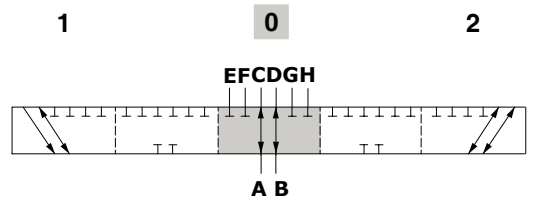

Spool stroke

Position 1: + 3.4 mm (0.13 in)
Position 2: - 3.4 mm (- 0.13 in)

Type I

Flow in C and D. E, F, G and H closed in pos. 0.

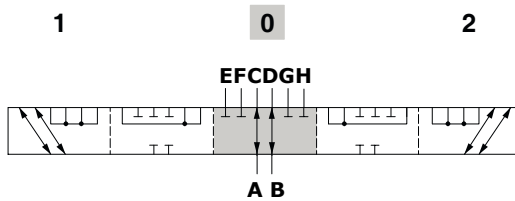

Spool stroke

Position 1: + 3.4 mm (0.13 in)
Position 2: - 3.4 mm (- 0.13 in)

Positioner kit

With spring return in position 1

Type 18W

With plug

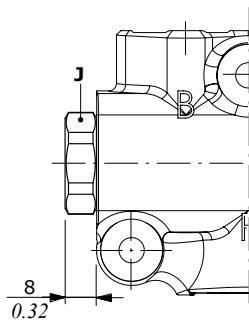

Type 18Y

With G1/4 drain port

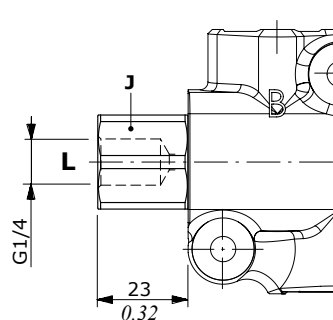

Wrenches and tightening torque

J = wrench 24 - 24 Nm (17.7 lbft)

Solenoid kit

ES tube assembly kit

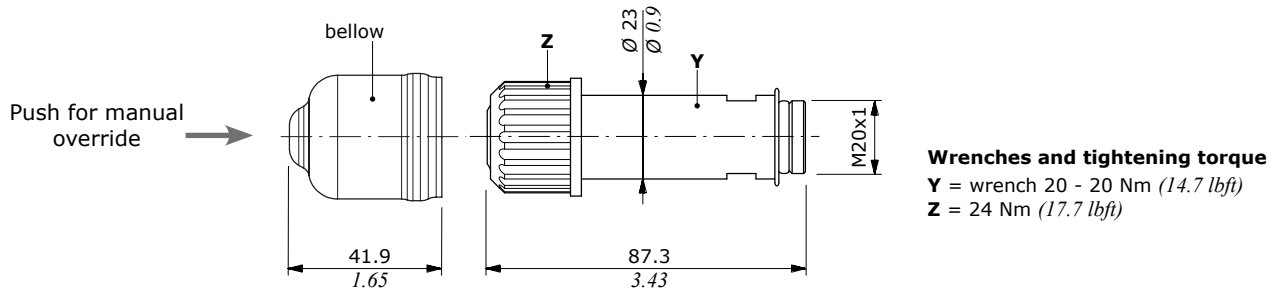

Positioner kit and solenoid kit - DFE052/8

With spring return in position 0

Tipo 8ES3

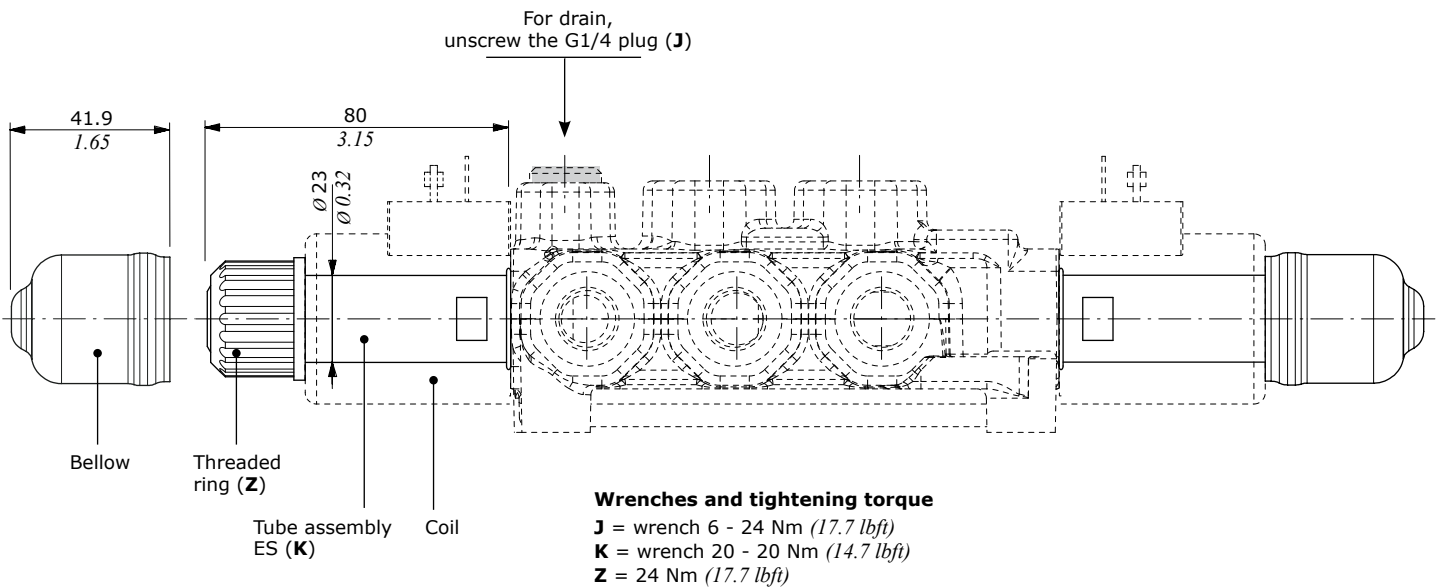
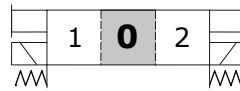

Coils and accessories

Type	Voltage	Ordering codes					Flying leads without connector
		ISO4400	Deutsch DT	AMP JPT	Packard Weatherpack	Packard Metri-pack	
D15	12 VDC	4SOL515012	4SOL515011 ⁽²⁾ 4SOL515014A ⁽³⁻⁶⁾	4SOL515016 ⁽⁵⁾	-	-	-
	14 VDC	-	4SOL515014B ⁽³⁻⁶⁾	4SOL515016A ⁽⁵⁾	-	-	-
	24 VDC	4SOL515024	4SOL515025A ⁽³⁻⁶⁾ 4SOL515021 ⁽²⁾	-	-	-	-
	48 VDC	4SOL515048	-	4SOL515049 ⁽²⁾	-	-	-
	98 VDC	4SOL515098	-	-	-	-	-
	110 VDC	4SOL515110	-	-	-	-	-
Mating connectors							
		4CN1009995	5CON140031	5CON003	-	-	-

Notes: (1) supply with AC and use only with rectifier connector - (2) with flying leads - (3) with bidirectional diode - (4) with unidirectional diode (5) integrated perpendicular type - (6) integrated parallel type

Features

- Nominal voltage tolerance: ±10%
- Nominal power.....: 38 W
- 12/14/24/48/98/110 VDC
- Nominal current.....: 3.16 A @ 12 VDC
- : 2.9 A @ 14 VDC
- : 1.58 A @ 24 VDC
- : 0.79 A @ 48 VDC
- : 0.41 A @ 98 VDC
- : 0.35 A @ 110 VDC
- Insulation.....: Class H (180°C - 356°F)
- Weather protection.....: IP65 - ISO4400
- : IP69K - Deutsch DT
- : IP65 - AMP JPT
- Insertion.....: 100%

ISO4400 connector

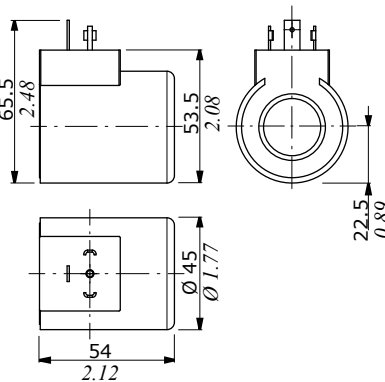

Flying leads with DEUTSCH DT04 connector

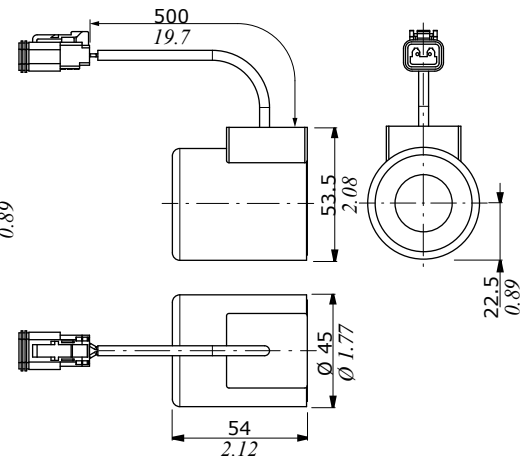

DEUTSCH DT04 connector (Parallel type)

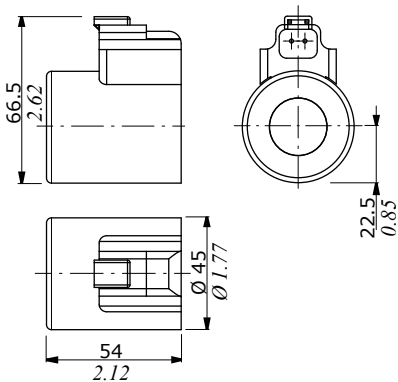

AMP JPT connector (Perpendicular type)

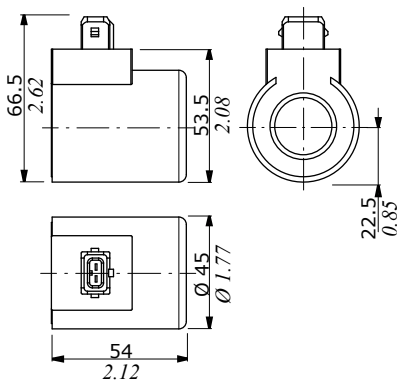

Flying leads with AMP JPT connector

